

Portable Modular Frame with Integrated Kitchen & Conveyor

GT10.2



Max. Speed **10,000 Gummies / hr**



Pneumatic Demolding Station



• **FEATURES** •

- Portable **Stainless Steel Frame** on Casters with **Integrated Kitchen, Conveyor & Depositor**
- New **Silicone Molds** with Internal **Stainless Steel Reinforcement** (Robust - 3 Pounds Each!)
- Precision **Servo Pump** - Accuracy +/- 2% by **Weight** - Best in Class
- 20 Liter **Jacketed Overhead Cooking & Mixing Vessel** w/ **Side & Bottom Teflon Scrapers**
- Adjustable **Tilt-Tank** for Ease of **Transferring Syrup** to Depositor
- **Servo-Cleated Conveyor** for Auto **Indexing of Tray / Molds** through Depositor
- 20 item **Batch Recipe Storage**. HMI Control Interface on both **Depositor & Kitchen**
- **10 Pistons** Depositor - Rated at **Max 25 Deposits / min** or **10,000 gummies / hr** (Dependent on Gummy Size)
- Easy Ejection - **Pneumatic De-molding Station** with Optional **Modular & Portable Drying Tray & Cart System**
- **Single Deposit Max Delivery** of 4.5 ml - Triple Deposit Capable
- All GMP, **FDA Approved Stainless Steel** Contact Parts

GT10.2 COMPACT GUMMY DEPOSITING SYSTEM



• 20 L KETTLE •



• DEPOSITOR •



• DEMOLDER •

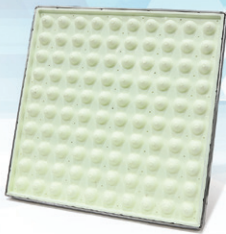

– Gummy Drop Mold –
Stainless Steel Reinforced Silicon



TECHNICAL SPECIFICATIONS

MODEL:	GT10.2
Production Capacity:	10,000 deposits / hr
Power Requirement:	230V / 1ph / 60Hz
Power Consumption:	20 Amps
Room Requirements for System:	
– Room Temperature:	22~25°C
– Humidity:	≤50% RH
Coating System Size:	W 38" x L 50" H 63"
Estimated Weight:	Approx. 500 lbs (all components included)
1 YEAR WARRANTY	

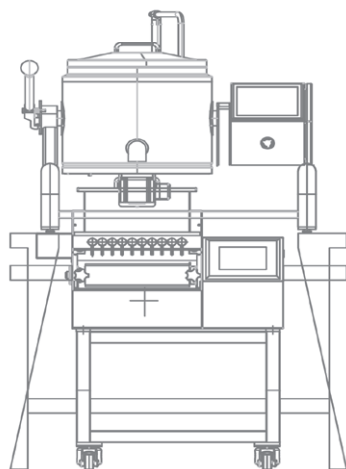

• Front View •

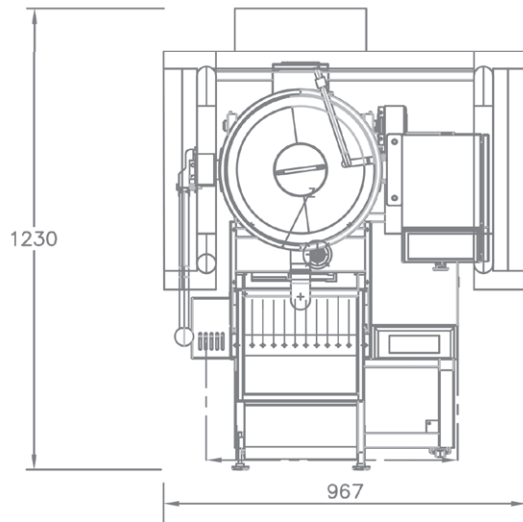

• Top View •

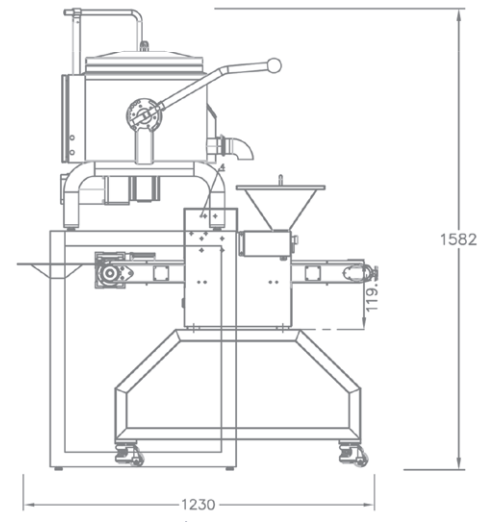

• Side View •